



Seismograph Revisited

By: Mark Spencer, WA8SME,
Former ARRL ETP Coordinator

Surprisingly, the Basic Stamp based seismograph project that was previously published is one of the more popular projects featured on the ARRL ETP projects web page. Requests for information on the seismograph peak with significant regional seismic activity around the globe. Based on feed back from readers, improvements in accelerometer technology, and to make the seismometer more flexible in demonstrating technologies based on acceleration sensors, a new and cheaper version of the seismometer was developed. In this article, the new version is described in brief. Additional, detailed information is available from the ARRL Education Services Department; etp@arrl.org.

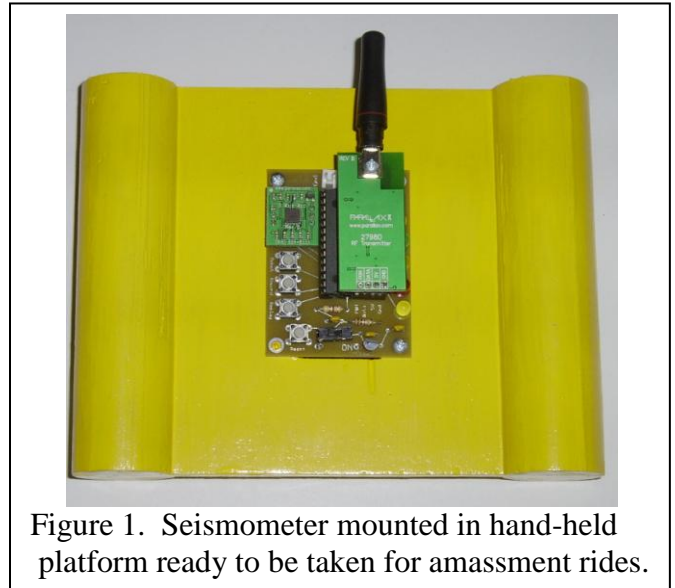

Figure 1. Seismometer mounted in hand-held platform ready to be taken for amassment rides.

The features of this new version include:

- PIC based to reduce costs, however at the expense of programming ease and flexibility
- Uses a 3-axis accelerometer in one module (also reducing costs)
- On-chip recording to allow taking the seismometer for a ride to measure accelerations
- Data can be data-linked (to break the umbilical cord) or sent direct to the computer via serial cable
- Push button mode select for live acceleration display, record for play back acceleration display, or live control of an appropriately equipped and programmed robot

Circuit and system description. The circuit diagram for this project is shown in figure 2. The central component of this circuit is the PIC16F876. This particular PIC is relatively easy to interface to serial devices which makes it adaptable to sending the collected data to a PC for data analysis and display. This PIC also allows the user to store data in the device's internal flash RAM that is normally used to store the PIC program. The Hitachi H48C accelerometer device has the X, Y and Z axis

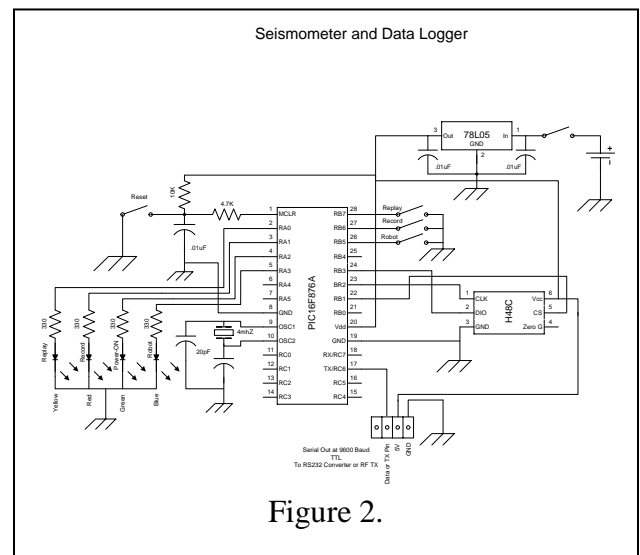

Figure 2.

accelerometers on one device.¹ Communication between the accelerometer and the PIC is via a serial data stream where the PIC sends a command to read a specific axis, and the accelerometer responds with the digital value that corresponds to the most recent measured acceleration on that axis. In turn, the PIC sends the X-Y-Z acceleration digital values to the PC running an Excel spreadsheet program (PLX-DAQ)² that puts the data into spreadsheet cells. Once the data is in Excel, the spreadsheet cells are programmed to convert the digital acceleration values into 'g' values and display the data graphically (figure 3). The various collection modes; record, play back, or control a robot, are selected by push buttons with associated LED indicators of the mode selected.

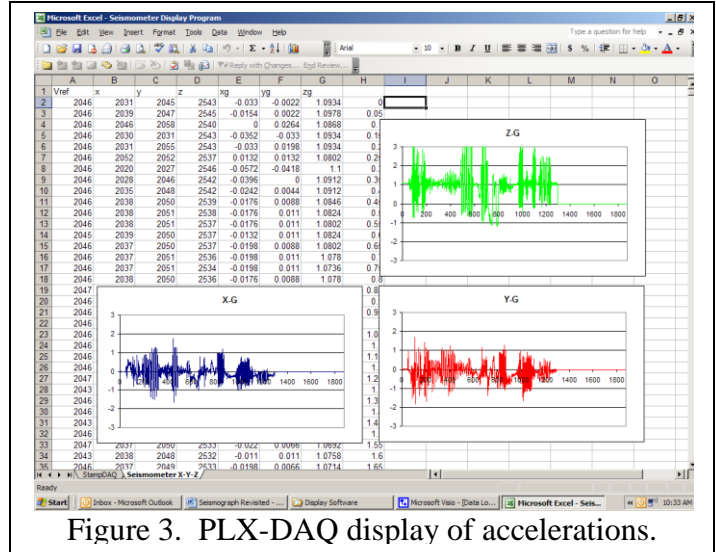

Figure 3. PLX-DAQ display of accelerations.

PIC Platform. The idea of using the PIC as the platform for the seismometer came from an article published in Nuts and Volts magazine.³ In that article, the author used the capability to store collected accelerometer data in the PIC16F876 flash RAM on the PIC device to record accelerations of a model rocket in flight. I adapted this concept to a more general project. The programming of the PIC16F876 is not a trivial activity but learning to program a PIC in assembly language is well worth the effort for those who are interested. The source code for this project is available upon request.

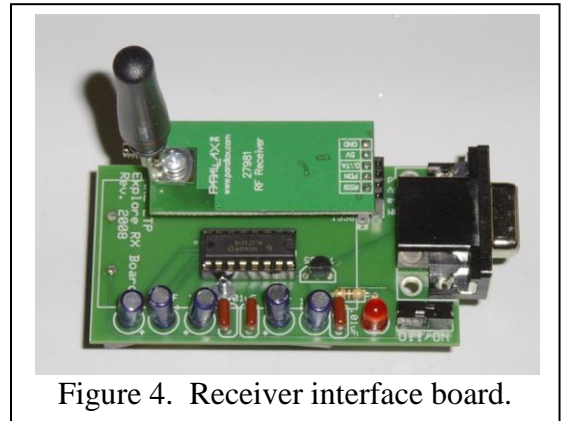
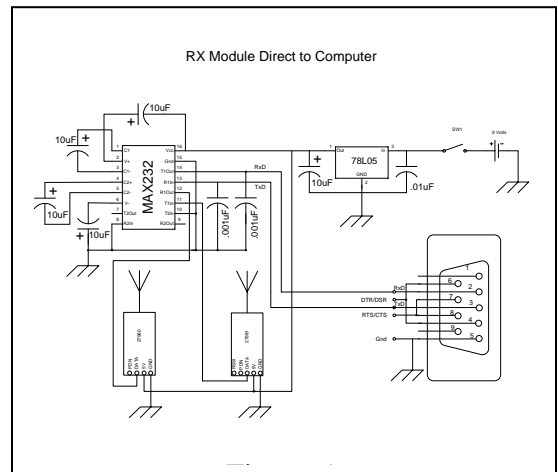

Figure 4. Receiver interface board.

Date Link. The data link components include the transmitter module⁴ mounted on the seismometer board and a receiver module⁵ mounted on a receiver interface board that is connected to the computer serial port. The receiver interface board is based on the MAX232 device that converts the TTL data from the receiver module into RS232 voltages acceptable to the computer serial port (figure 4 and 5). I use this receiver module for numerous other projects that require receiving data for display in Excel.



Excel Program. The Excel program is available off the web from Parallax². This program is a sub utility program that allows the data received via the computer serial port in a specific

format to be captured and put into sequential cells within Excel. Once in Excel, the user can use the power of Excel to manipulate and display the data. This is a very powerful tool that deserves some exploration.

Applications

Live collection. Connect the seismometer to the computer via the serial cable connector or install the data link transmitter module in the connector jack on the seismometer and connect the receiver board to the computer serial port. Launch the PLX-DAQ software on the computer and connect to the serial port. When power is applied to the seismometer, the acceleration data will begin to be displayed on the X-Y-Z graphs (figure 3). The basics of seismology can be demonstrated by shaking the seismometer to simulate an earthquake. Slowly tilting the seismometer in each of the axis will show the accelerations change +/- 1 g, depending on the orientation of the seismometer in relation to the earth's surface. A limited amount of data is displayed on the graphs using the default settings in the PLX-DAQ program that I have adapted to this project, the user can easily change these values to display more data, or display the data in more detail by adjusting these graph settings within Excel.

Recording collection. The seismometer can be used to explore accelerations in various contexts (amusement rides or transportation means) by recording approximately 1.5 minutes of acceleration data. In this mode, the seismometer can be used stand alone, or the transmitter module can be installed. If the transmitter is installed, the data will be collected and stored and also transmitted live back to the receiver module. To record, press the record button, the recording LED will illuminate. When the RAM is full, the record LED will flash.

Playback. To retrieve the recorded data, either connect the seismometer to the computer via the serial cable or install the transmitter module. Launch PLX-DAQ and connect to the seismometer. Press the reset button. When the replay button is pressed, the associated LED will illuminate and the data will be dumped to the Excel spreadsheet. When the dump is complete, the LED will flash. The data is not lost in the PIC and can be downloaded again if desired.

Robot control. Many of today's video games include a user input device based on accelerations. The Wii© game system comes to mind where a simulated automobile steering wheel is the input device for a game. The seismometer can be used with an appropriately equipped and programmed robot to allow the user to control the robot movement by tilting the seismometer either forward, back, left, or right. In this case, a Parallax BOE-BOT has a receiver module mounted on the prototyping area of the BOT and the BOT is programmed to recognize changes in the X and Y

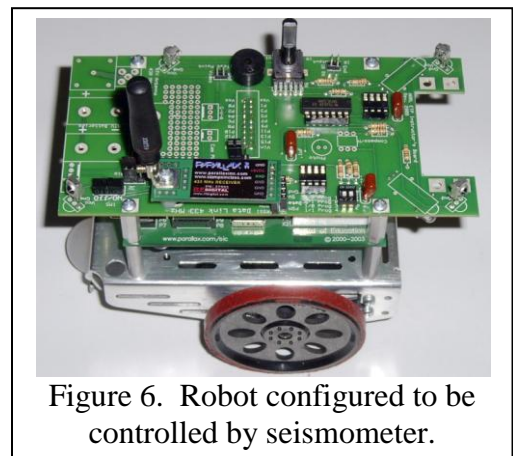
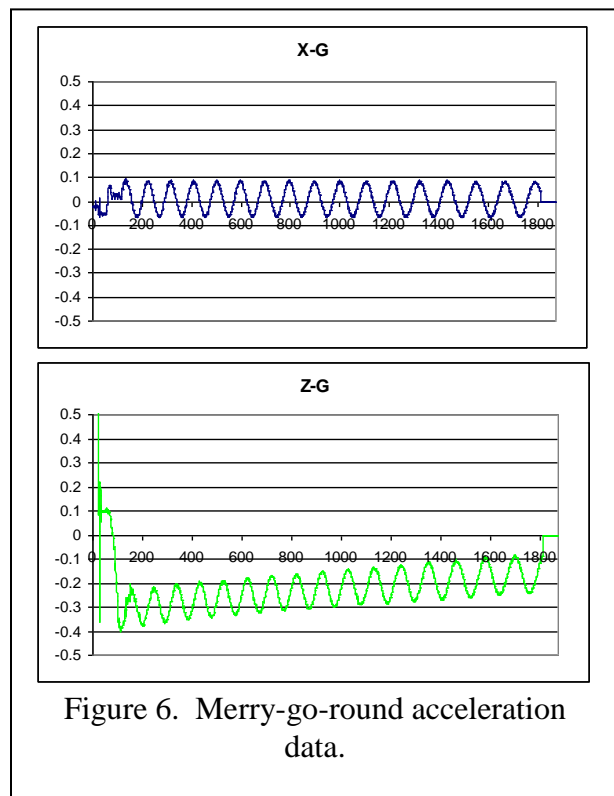

Figure 6. Robot configured to be controlled by seismometer.

accelerations sent from the seismometer and respond by moving accordingly. In this demonstration, turn on the robot, turn on the seismometer and press the robot button. As you tilt the seismometer, the robot will move in the commanded direction.

Playground activity. One use of the seismometer is to study the acceleration on different rides in a child's playground. I took the seismometer on a swing, merry-go-round, and slide and recorded the accelerations. The graphs of the accelerations were printed and given to students to analyze the data and identify which graphs correspond to the rides based on their analysis of the acceleration data.

Summary. This project covers many different Physical Science content areas that involve Force and Acceleration as well as Environmental Science content areas that involve earthquakes. This device allows for many fun, hands-on experiments that students can enjoy while studying the forces that they experience every day in a quantitative way.



Notes:

1. Accelerometer Device:

<http://www.parallax.com/Store/Sensors/AccelerationTilt/tabid/172/CategoryID/47/List/0/Level/a/ProductID/97/Default.aspx?SortField=ProductName%2cProductName>

2. PLX-DAQ software download location:

<http://www.parallax.com/tabid/441/Default.aspx>

3. Nuts and Volts, January 2008, "Single Chip, Four Channel Datalogger", by David Gravatt, page 42.

4. Data link transmitter:

<http://www.parallax.com/Store/Accessories/Communication/tabid/161/CategoryID/36/List/0/Level/a/ProductID/113/Default.aspx?SortField=ProductName%2cProductName>

5. Data link receiver:

<http://www.parallax.com/Store/Accessories/Communication/tabid/161/CategoryID/36/List/0/Level/a/ProductID/112/Default.aspx?SortField=ProductName%2cProductName>

© Copyright 2003-2010 American Radio Relay League, Inc. all rights reserved. This content is intended for educational purposes. When used for this purpose, please acknowledge ARRL as the source. Additional permission is required to use this material in any training or product that will be redistributed or used for re-sale.